

BILSTEIN®

B8 8112 (ZoneControl® CR)

BILSTEIN B8 8112 (ZoneControl® CR).

Damping perfected.

Never before has so much capability been packed into one direct fit suspension kit. BILSTEIN B8 8112 (ZoneControl® CR) suspension kits incorporate a new, revolutionary technology, delivering position sensitive damping in both compression and rebound. ZoneControl® CR provides unparalleled comfort during everyday driving conditions, combined with maximum control under large suspension inputs. BILSTEIN B8 8112 (ZoneControl® CR) suspension kits will enhance your suspension performance to a level that will defy convention.

Features & benefits:

- ZoneControl® CR: Position sensitive damping with 3 compression zones and 2 rebound zones, controlled by 3 independent pistons
 - Compression (C): Provides superior bottom out control through a 2-stage, telescoping internal compression stop. This feature eliminates the need for an external hydraulic bump stop
 - Rebound (R): Secondary rebound stop will dissipate spring energy and stabilize the suspension directly following a large compression event. The internal rebound stop will also eliminate harsh top-out events and the need for an external limit strap
- Triple piston design delivers comfort during every day driving conditions and maximum control under large suspension inputs
- Adjustable threaded spring seat allows for fine-tuned ride height. Adjustable range .6-2.5in
- 60mm remote reservoir for increased oil capacity and cooling
- Vehicle specific design and tuning provides the ultimate driving experience. Aerospace quality components are vehicle specific to optimize wheel travel and clearance
- High quality chrome 5/8" heim joint mounting with rubber sealed misalignment spacers offer the most durable, load bearing mount solution
- Aluminum components with zinc plated shock bodies will resist harsh off-road elements
- Coilover supplied as a complete module for easy installation. Spring is pre-loaded to the factory recommended ride height
- Factory rebuildable
- Made in the USA



1. Frame Mounts

B8 8112 shock absorbers include a vehicle specific aluminum anodized reservoir frame mount.





ZoneControl® CR.

ZoneControl® CR delivers position sensitive damping with 3 compression zones and 2 rebound zones, controlled by 3 independent pistons. Three key internal features produce ZoneControl® CR:

- JCO System
- Triple Piston Design
- RCO System

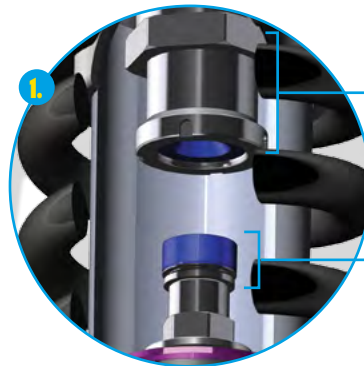

Telescoping Internal Compression Stop

JCO Secondary Compression Valve Piston

JCO System (Jounce Cut Off)

The JCO system is comprised of two components: the JCO secondary compression valve piston and the 2-stage telescoping compression stop.

The JCO system provides bottom out control when the JCO secondary compression valve piston engages the 2-stage telescoping internal compression stop. This feature eliminates the need for an external hydraulic bump stop.

Triple Piston Design

ZoneControl® CR features a triple piston design for unparalleled comfort during every day driving conditions without sacrificing maximum control off-road.

The 3 independent working pistons include:

- JCO (Jounce Cut Off) secondary compression valve piston
- Main 60mm digressive piston
- RCO (Rebound Cut Off) secondary rebound valve piston

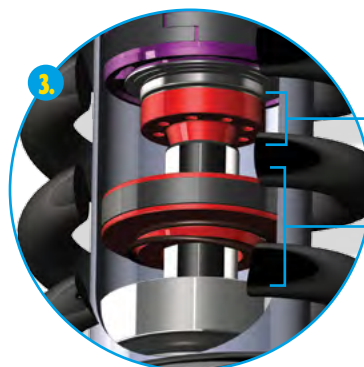
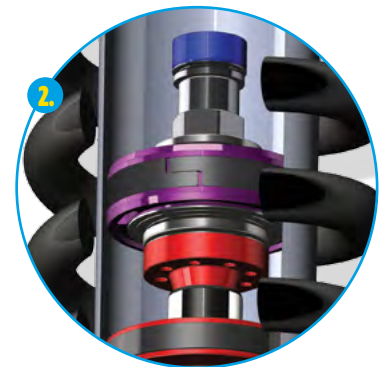

RCO Secondary Rebound Valve Piston

Internal Rebound Stop

RCO System (Rebound Cut Off)

The RCO system is comprised of two components: the RCO secondary rebound valve piston and the internal rebound stop.

The RCO system effectively decelerates the spring when the RCO secondary rebound valve piston engages the internal rebound stop.

| Model | Year | Lifted Height | | Front Kit | | Rear Shock | | Note |
|---------------|--------|---------------|--------|-----------|---------|------------|------------------|------------|
| | | Front | Rear | Part # | Series | Part # | Series | |
| Toyota Tacoma | 05-'15 | .6-2.5" | 0-1.5" | 47-269279 | B8 8112 | 25-269802 | B8 8100 (Bypass) | Rear Left |
| | | | | | | 25-269819 | B8 8100 (Bypass) | Rear Right |